

BO4840NH2B \varnothing 48mm*38.5mm, 外转子带传感器 Outer Rotor, Sensored

应用领域: 无人机、电动工具、自动化设备、智能家居等驱动领域。

Applications: UAV, electrical tools, automation equipment, smart home, etc.

				01-105-18.0	02-105-24.0	03-105-36.0
电机参数 / Motor Data						
1	电压	Voltage	V	18.0	24.0	36.0
2	端电阻	Terminal resistance	Ω	0.034	0.053	0.11
3	空载转速	No-load speed	rpm	10500	10500	10500
4	空载电流	No-load current	A	1.6	1.2	0.9
5	堵转转矩	Stall torque	mNm	8614	9831	10656
6	堵转电流	Stall current	A	529.4	452.8	327.3
7	额定转矩	Nominal torque	mNm	423	427	420
8	额定转速	Nominal speed	rpm	9350	9400	9440
9	额定电流	Nominal current	A	25.7	19.5	12.9
10	最大输出功率	Max. output power	W	2367	2701	2928
11	最大效率	Max. efficiency	%	89.2	89.9	89.7
12	反电势常数	Back-EMF constant	mV/rpm	1.7	2.3	3.4
13	转矩常数	Torque constant	mNm/A	16.3	21.8	32.7
14	KV 值	KV Value	rpm/V	583	437.5	292
15	转速 / 转矩斜率	Speed/torque gradient	rpm/mNm	1.22	1.07	0.99
16	转子惯量	Rotor inertia	gcm^2	398	398	398
17	重量	Weight	g	267	267	267

热参数 / Thermal Data			
18	热阻 (机壳 - 环境)	Thermal resistance housing-ambient	K/W 0.9
19	热阻 (线圈 - 机壳)	Thermal resistance winding-housing	K/W 1
20	热时常数 (电机)	Thermal time constant motor	s 300
21	热时常数 (线圈)	Thermal time constant winding	s 60
22	工作温度范围	Operating temperature range	$^{\circ}\text{C}$ -40~+120
23	绕组耐温等级	Thermal class of winding	$^{\circ}\text{C}$ 180

特性曲线 / Characteristics Curve

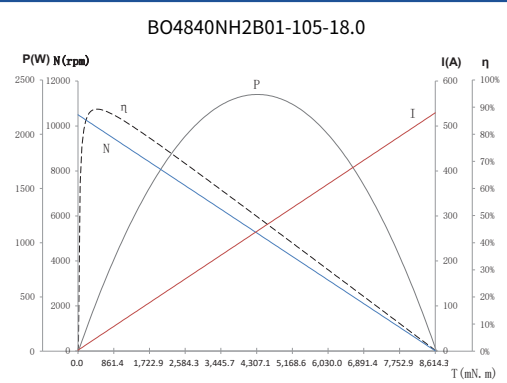

机械参数 / Mechanical Data			
24	轴向间隙	Axial play	mm 0.012
25	径向间隙	Radial play	mm 0.008
26	动态轴向载荷	Axial load dynamic	N 10
27	静态轴向载荷	Axial load static	N 110
28	径向载荷 (距安装面 3mm)	Radial load at 3 mm from mounting face	N 42

其它参数 / Other Specifications			
29	极对数	No. of pole pairs	7
30	滚珠轴承	Ball bearings	2
31	换向结构	Commutation structure	hall sensor
32	防护等级	Protection class	IP20

— 转速 (N) — 电流 (I) - - - 效率 (η)
 — 功率 (P)
 仅供参考, 详细了解请以产品规格书为准。
 For reference only, please refer to the product specification.

端子定义 / Connection

可选配置 / Options

齿轮箱: 行星齿轮 Gearbox: planetary gearbox
 性能 Special coils: 连续运行范围内可定制 customizable in continuous operation range
 编码器 Encoder/ 驱动器 Driver: 可定制 customizable upon request
 法兰 Flange: 标准前后法兰 standard front and rear flanges / 定制法兰 custom flanges
 轴 Shaft: 长度 length / 异形 shape
 轴承类型 Bearing type: 含油轴承 sleeve bearings / 滚珠轴承 ball bearings
 电气连接 Electrical connection: 端子或导线 connector or wire / 导线长度 lead wires length

A 霍尔传感器 / hall sensor AWG 24/AWG 16				B 无传感器 / sensorless AWG 16			
Pin1	H-	black	Pin1	U	black		
Pin2	Hv	yellow	Pin2	V	yellow		
Pin3	Hv	white	Pin3	W	red		
Pin4	Hu	blue					
Pin5	H+	red					
Pin6	U	black					
Pin7	V	yellow					
Pin8	W	red					

外观图 / Outline Drawing

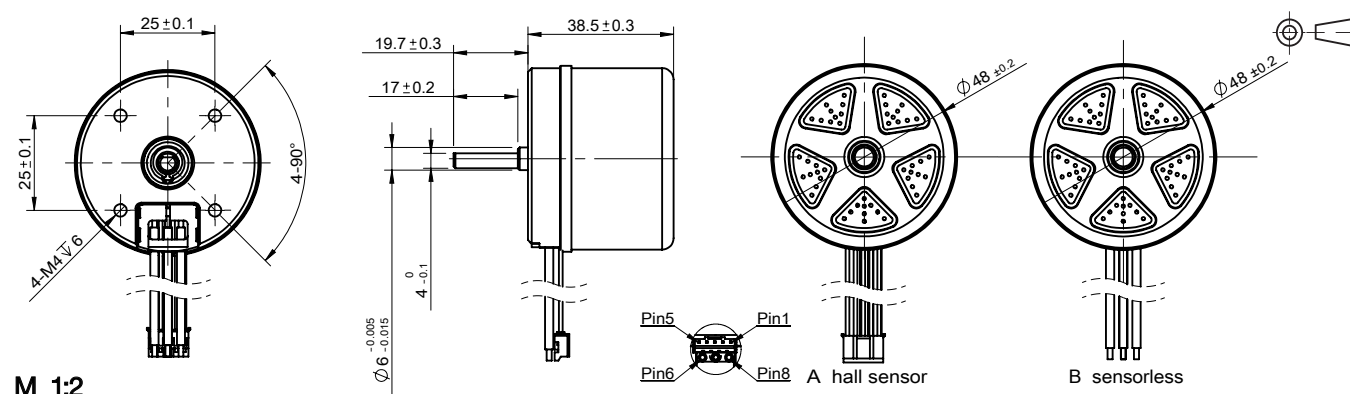

规格如有变更, 恕不另行通知。Specification subject to change without notice.