

BO3850NH3B $\varnothing 37.6\text{mm} \times 50\text{mm}$, 外转子带传感器 Outer Rotor, Sensored

应用领域: 无人机、电动工具、自动化设备、机器人等驱动领域。

Applications: UAV, electrical tools, automation equipment, robotics, etc.

精密直流空心杯电机
PRECISION DC CORELESS MOTOR

无刷电机
BRUSHLESS DC MOTOR

驱动器
CONTROLLER

精密齿轮减速电机
PRECISION GEAR MOTOR

精密伺服电机
PRECISION SERVO MOTOR

直流空心杯电机
DC CORELESS MOTOR

直流铁芯电机
DC CORE MOTOR

声波振动电机
SONIC MOTOR

全球营销网络
GLOBAL MARKETING NETWORK

	01-88-24.0	01-88-36.0	01-88-48.0
--	------------	------------	------------

电机参数 / Motor Data

1 电压	Voltage	V	24.0	36.0	48.0
2 端电阻	Terminal resistance	Ω	0.1	0.23	0.39
3 空载转速	No-load speed	rpm	8800	8800	8800
4 空载电流	No-load current	A	1	0.7	0.5
5 堵转转矩	Stall torque	mNm	6198	6060	6358
6 堵转电流	Stall current	A	240	156.5	123.1
7 额定转矩	Nominal torque	mNm	346	345	347
8 额定转速	Nominal speed	rpm	7650	7480	7850
9 额定电流	Nominal current	A	13.1	8.5	6.7
10 最大输出功率	Max. output power	W	1427	1395	1464
11 最大效率	Max. efficiency	%	87.5	87	87.6
12 反电势常数	Back-EMF constant	mV/rpm	2.7	4.1	5.4
13 转矩常数	Torque constant	mNm/A	25.9	38.9	51.9
14 KV 值	KV Value	rpm/V	367	244	183
15 转速 / 转矩斜率	Speed/torque gradient	rpm/mNm	1.42	1.45	1.38
16 转子惯量	Rotor inertia	gcm^2	228	228	228
17 重量	Weight	g	198	198	198

热参数 / Thermal Data

18 热阻 (机壳 - 环境)	Thermal resistance housing-ambient	K/W	1.1
19 热阻 (线圈 - 机壳)	Thermal resistance winding-housing	K/W	1.2
20 热时常数 (电机)	Thermal time constant motor	s	350
21 热时常数 (线圈)	Thermal time constant winding	s	63
22 工作温度范围	Operating temperature range	$^{\circ}\text{C}$	-40~+100
23 绕组耐温等级	Thermal class of winding	$^{\circ}\text{C}$	180

特性曲线 / Characteristics Curve

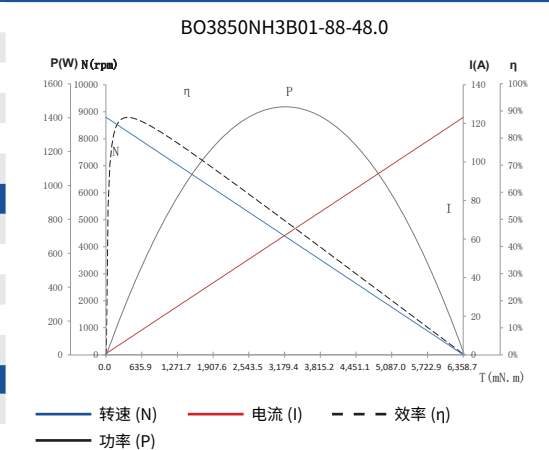

机械参数 / Mechanical Data

24 轴向间隙	Axial play	mm	0.012
25 径向间隙	Radial play	mm	0.008
26 动态轴向载荷	Axial load dynamic	N	8
27 静态轴向载荷	Axial load static	N	110
28 径向载荷 (距安装面 3mm)	Radial load at 3 mm from mounting face	N	31

其它参数 / Other Specifications

29 极对数	No. of pole pairs		7
30 滚珠轴承	Ball bearings		3
31 换向结构	Commutation structure	hall sensor	
32 防护等级	Protection class		IP20

可选配置 / Options

齿轮箱: 行星齿轮
Gearbox: planetary gearbox

性能 Special coils: 连续运行范围内可定制 customizable in continuous operation range

编码器 Encoder/ 驱动器 Driver: 可定制 customizable upon request

法兰 Flange: 标准前后法兰 standard front and rear flanges / 定制法兰 custom flanges

轴 Shaft: 长度 length / 异形 shape

轴承类型 Bearing type: 含油轴承 sleeve bearings / 滚珠轴承 ball bearings

电气连接 Electrical connection: 端子或导线 connector or wire / 导线长度 lead wires length

端子定义 / Connection

A 霍尔传感器 / hall sensor AWG 24/AWG 28			B 无传感器 / sensorless AWG 18		
Pin1	H-	black	Pin1	U	black
Pin2	Hv	yellow	Pin2	V	yellow
Pin3	Hv	white	Pin3	W	red
Pin4	Hu	blue			
Pin5	H+	red			
Pin6	U	black			
Pin7	V	yellow			
Pin8	W	red			

外观图 / Outline Drawing

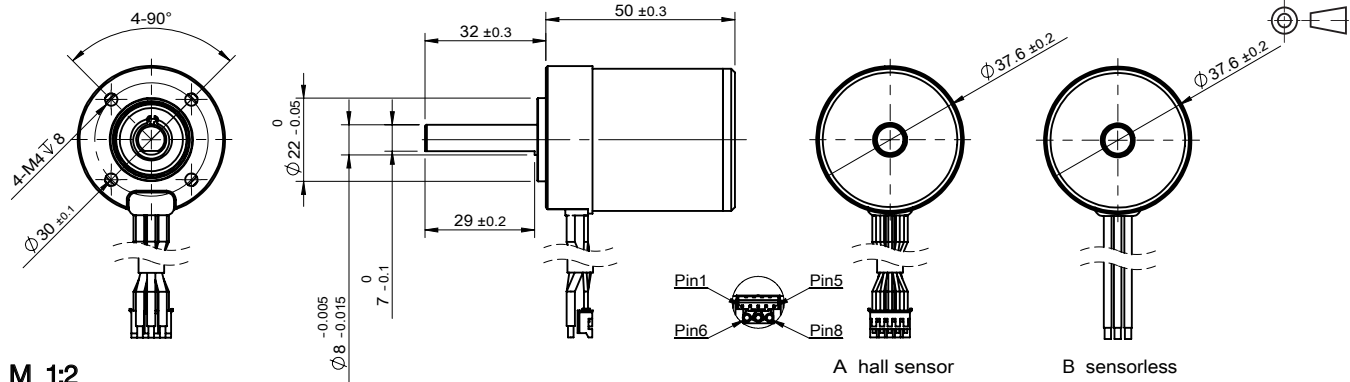

M 1:2