

# BO4416N2B $\varnothing 43.95\text{mm} \times 16\text{mm}$ , 外转子无传感器 Outer Rotor, Sensorless

应用领域: 无人机、电动工具、自动化设备、智能家居等驱动领域。

Applications: UAV, electrical tools, automation equipment, smart home, etc.

	02-34-12.0	03-34-18.0	04-24-24.0
--	------------	------------	------------

电机参数 / Motor Data			
1 电压	Voltage	V	12.0
2 端电阻	Terminal resistance	$\Omega$	0.37
3 空载转速	No-load speed	rpm	3450
4 空载电流	No-load current	A	0.3
5 堵转转矩	Stall torque	mNm	1057
6 堵转电流	Stall current	A	32
7 额定转矩	Nominal torque	mNm	95
8 额定转速	Nominal speed	rpm	3100
9 额定电流	Nominal current	A	3.2
10 最大输出功率	Max. output power	W	95
11 最大效率	Max. efficiency	%	81
12 反电势常数	Back-EMF constant	mV/rpm	3.4
13 转矩常数	Torque constant	mNm/A	33
14 电感	Terminal inductance	mH	290
15 转速 / 转矩斜率	Speed/torque gradient	rpm/mNm	3.3
16 转子惯量	Rotor inertia	$\text{gcm}^2$	70
17 重量	Weight	g	66

热参数 / Thermal Data				特性曲线 / Characteristics Curve			
18 热阻 (机壳 - 环境)	Thermal resistance housing-ambient	K/W	8.9				
19 热阻 (线圈 - 机壳)	Thermal resistance winding-housing	K/W	2.7				
20 热时常数 (电机)	Thermal time constant motor	s	325				
21 热时常数 (线圈)	Thermal time constant winding	s	252				
22 工作温度范围	Operating temperature range	$^{\circ}\text{C}$	-40~+120				
23 绕组耐温等级	Thermal class of winding	$^{\circ}\text{C}$	180				

机械参数 / Mechanical Data			
24 轴向间隙	Axial play	mm	0.014
25 径向间隙	Radial play	mm	0.008
26 动态轴向载荷	Axial load dynamic	N	5
27 静态轴向载荷	Axial load static	N	80
28 径向载荷 (距安装面 3mm)	Radial load at 3 mm from mounting face	N	29

其它参数 / Other Specifications			
29 极对数	No. of pole pairs		12
30 滚珠轴承	Ball bearings		2
31 换向结构	Commutation structure		sensorless
32 防护等级	Protection class		IP20

### 端子定义 / Connection

可选配置 / Options	A 霍尔传感器 / hall sensor		B 无传感器 / sensorless	
齿轮箱: 行星齿轮	AWG 26		AWG 22	
性能 Special coils: 连续运行范围内可定制 customizable in continuous operation range	Pin1	Hw	Pin1	U
编码器 Encoder/ 驱动器 Driver: 可定制 customizable upon request	Pin2	Hv	Pin2	V
法兰 Flange: 标准前后法兰 standard front and rear flanges / 定制法兰 custom flanges	Pin3	Hu	Pin3	W
轴 Shaft: 长度 length / 异形 shape	Pin4	+		
轴承类型 Bearing type: 含油轴承 sleeve bearings / 滚珠轴承 ball bearings	Pin5	-		
电气连接 Electrical connection: 端子或导线 connector or wire / 导线长度 lead wires length	Pin6	U		
	Pin7	W		
	Pin8	V		

### 外观图 / Outline Drawing

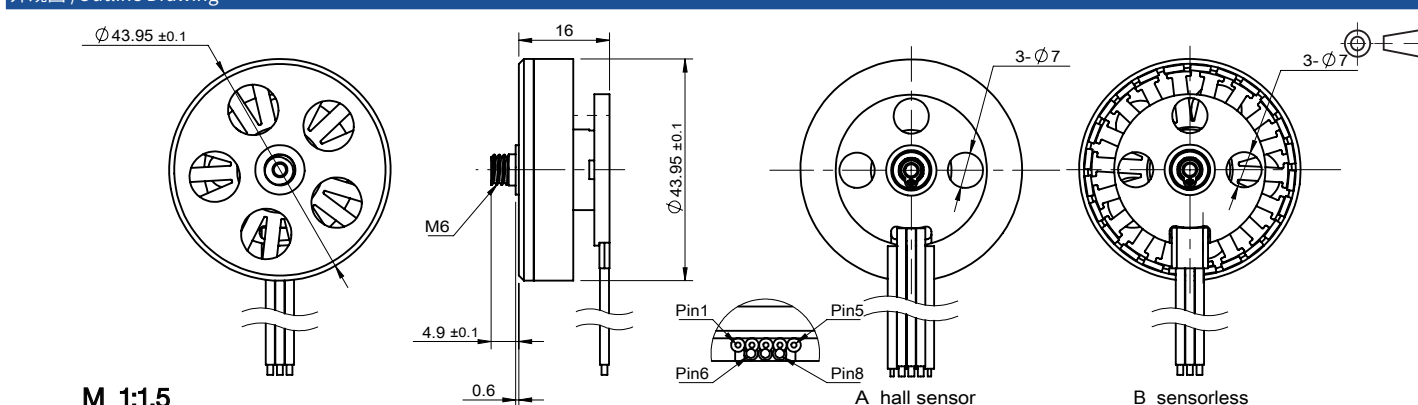

规格如有变更, 恕不另行通知。Specification subject to change without notice.

www.constarmotor.com

精密直流空心杯电机 PRECISION DC CORELESS MOTOR  
 无刷电机 BRUSHLESS DC MOTOR  
 驱动器 CONTROLLER  
 精密齿轮减速电机 PRECISION GEAR MOTOR  
 精密伺服电机 PRECISION SERVO MOTOR  
 直流空心杯电机 DC CORELESS MOTOR  
 直流铁芯电机 DC CORE MOTOR  
 声波振动电机 SONIC MOTOR  
 全球营销网络 GLOBAL MARKETING NETWORK